

Digital output oil filled pressure sensing element



Features

- Low cost OEM
- Range:0.4 to 70bar
- $\pm 0.5\%$ Total Error Band
- Temperature compensated
- Standard mounting size
- I²C or SPI Interface protocols
- Compatible with corrosive media

Application

- Process Automation & Control
- Fresh and waste water
- Pressure transmitters
- Medical instruments

Performance

Pressure range(FS)	1~70 bar
Accuracy(nonlinearity+hysteresis+repeatability)	$\pm 0.1\%$ FS
Total error band(typical)	$\pm 0.5\%$
Interface type	I ² C(ADDR,0X28H)/SPI
Output type(A type)	10%~90%
Output type(B type)	5%~95%
Excitation voltage	2.7~5.5Vdc
Excitation voltage(typical)	3.3Vdc
Current consumption(Non-Sleep)	2.7mA
Current consumption(Sleep mode)	2 μ A
Zero pressure output	666
Full scale output	399A
Resolution(14bits)	0.008% FS
Response frequency(typical)	2KHz
Load resistance	>10K Ω
Insulation resistance(@50V)	>50M Ω

Environmental

Operate temperature	-40 to 125°C
Compensated temperature	-10 to 70°C
Temperature accuracy(-10~70°C)	$\pm 2^\circ$ C
Temperature resolution(8~11bits)	0.12°C
Overload	>2 * FS
Overload(70 bar only)	>1.5 * FS
Media	#316L SS compatible
Housing	#316L SS
Electrical connection	Ribbon Cable or Connect Pins

Total error band including: calibration errors and temperature effects over the compensated range.

CE Compliance:

EN55022 Emissions Class A&B
IEC61000-4-2(ESD):8KV(air)/6KV(contact)
IEC61000-4-3 Radiated, Radio-Frequency Electromagnetic Field Immunity (3V/m, 80MHZ~1GHZ)
IEC61000-4-4 Electrical Fast Transient Immunity (1KV)
IEC61000-4-6 Immunity to Conducted Disturbances Induced by Radio Frequency Fields(150KHZ~80MHZ 3V Level)
IEC61000-4-9 Pulse Magnetic Field Immunity (100A/m Peak)

Dimensions(mm):

Ribbon Cable:

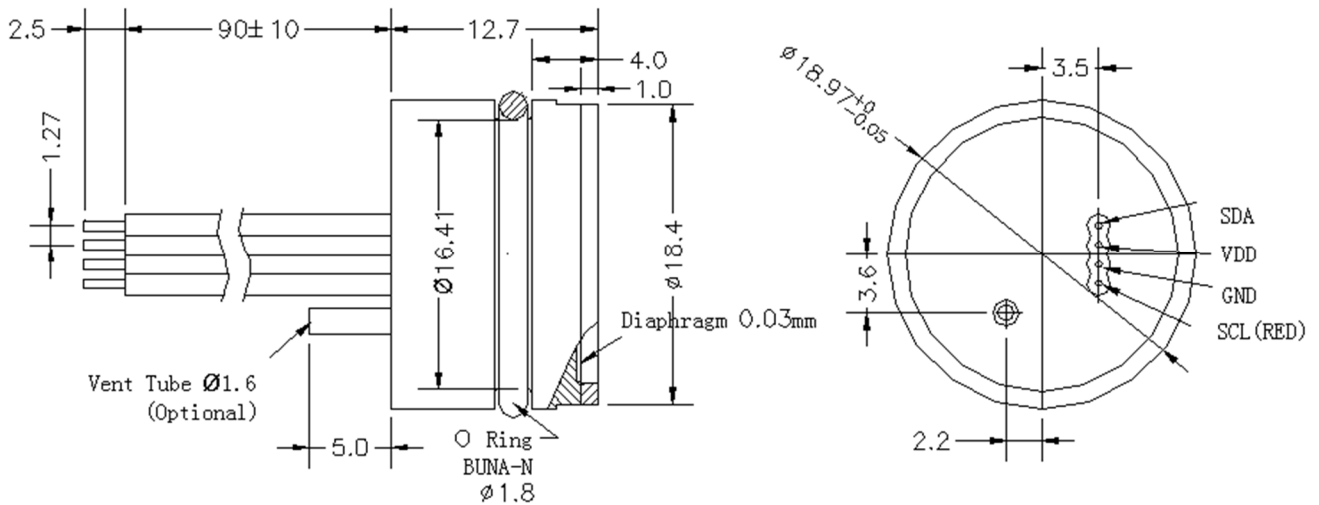

Connect Pins:

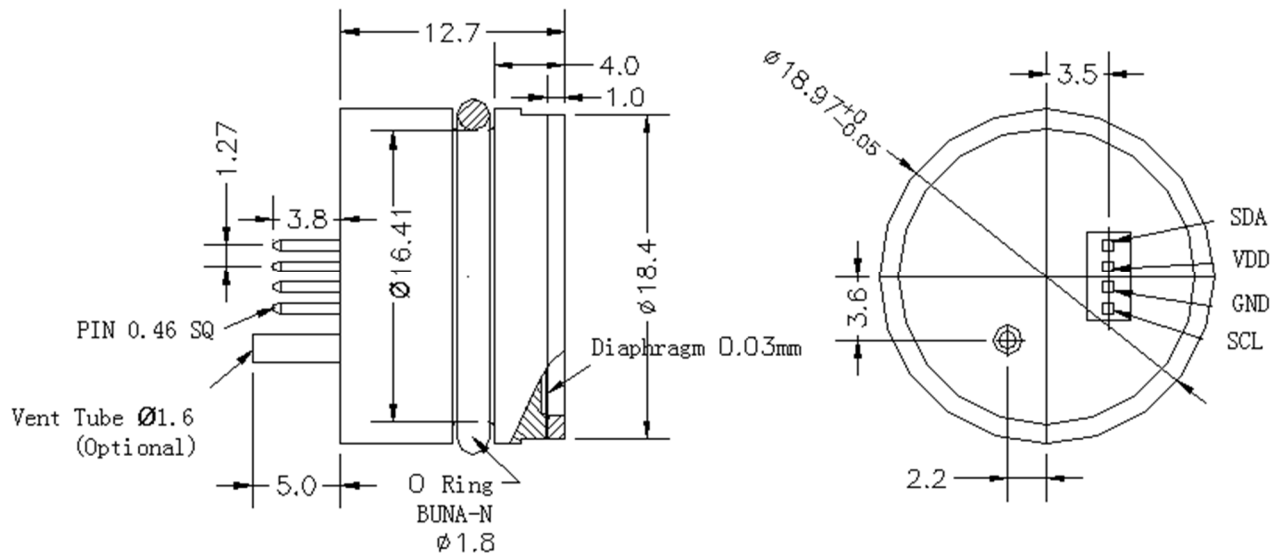

Remark: Ribbon Cable or Connect Pins are optional for all models.

Maximum temperature range for standard cable is -20°C to +105

Ordering information:

P3401	R1A	-	10B	-	A	-	R
Model	Output type	-	Range	-	Reference type	-	Connector type
P3401	R= Digital output 1= I ² C interface 2= SPI interface A= A type: 10%~90% B= B type: 5%~95%	-	0.4B= 0.4 bar 1B= 1 bar 1.6B= 1.6 bars 4B= 4 bars 6B= 6 bars 10B= 10 bars 16B= 16 bars 25B=25 bars 40B= 40 bars 70B= 70 bars	-	A= Absolute(not for <1bar range) G= Gauge pressure T= Gauge pressure with vent Tube S= Sealed gage	-	R= 90mm Ribbon cable C= Connect pins

Output Transfer:

Pressure:

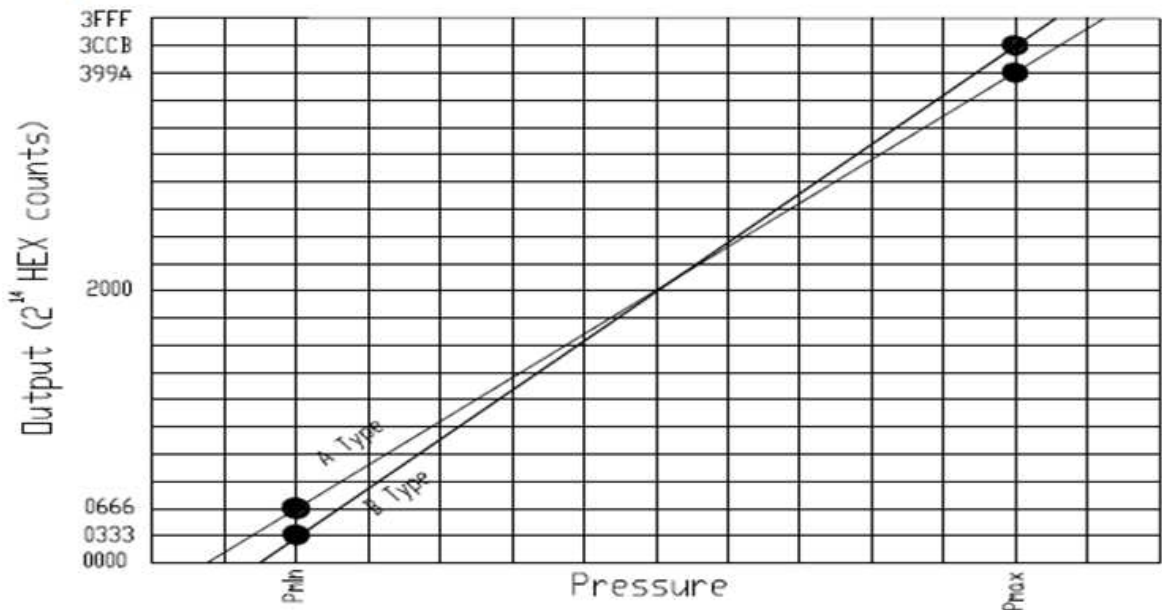

$$\text{A Type: Output (Decimal counts)} = \frac{80\% * 16383}{P_{\text{max}} - P_{\text{min}}} * (\text{Pressure}_{\text{applied}} - P_{\text{min}}) + 10\% * 16383$$

$$\text{B Type: Output (Decimal counts)} = \frac{90\% * 16383}{P_{\text{max}} - P_{\text{min}}} * (\text{Pressure}_{\text{applied}} - P_{\text{min}}) + 5\% * 16383$$

Sensor Output at Significant Percentages

% Output	Digital Counts (decimal)	Digital Counts (hex)
0	0	0 X 0000
5	819	0 X 0333
10	1638	0 X 0666
50	8192	0 X 2000
90	14746	0 X 399A
95	15563	0 X 3CCB
100	16383	0 X 3FFF

Temperature:

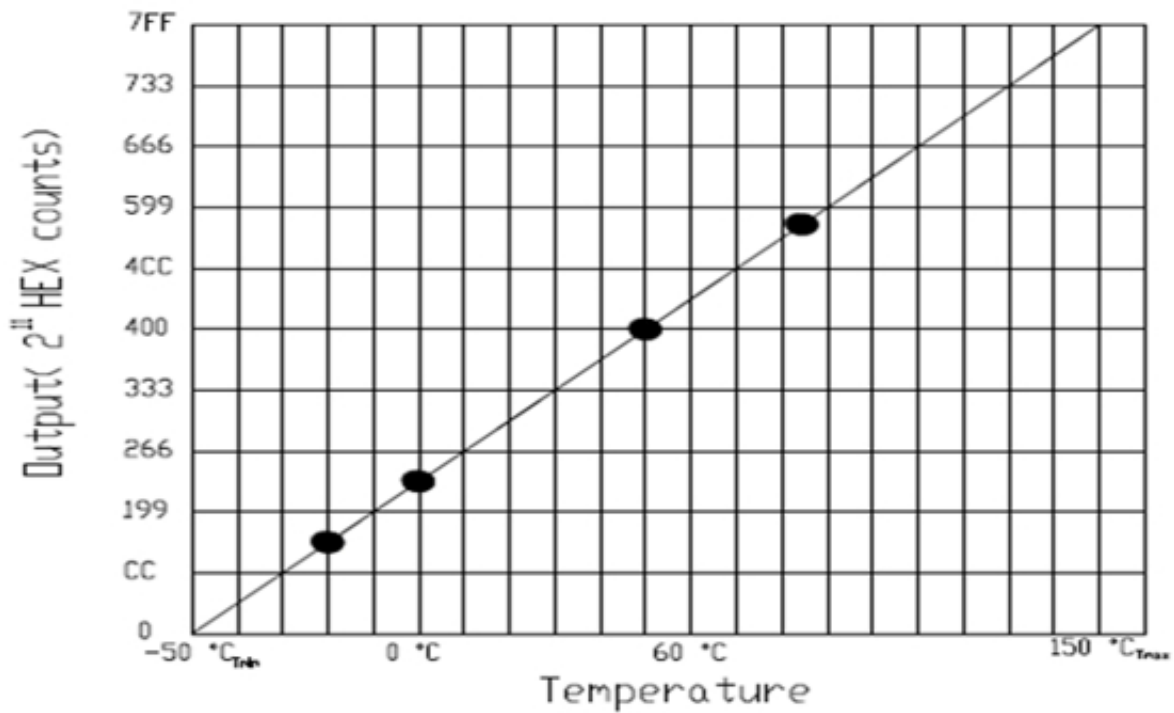

$$\text{Output (Decimal Counts)} = \frac{(\text{Output } ^\circ\text{E } (-50^\circ\text{C})_{T_{\min}}) \# 2047}{(150^\circ\text{C}_{T_{\max}} - (-50^\circ\text{C})_{T_{\min}})}$$

Temperature Output vs Counts

Output °C	Digital Counts (decimal)	Digital Counts (hex)
-50	0	0 X 0000
0	512	0 X 0200
10	614	0 X 0266
25	767	0 X 02FF
40	921	0 X 0399
85	1381	0 X 0565
150	2047	0 X 07FF

I²C command setting and digital sequence:

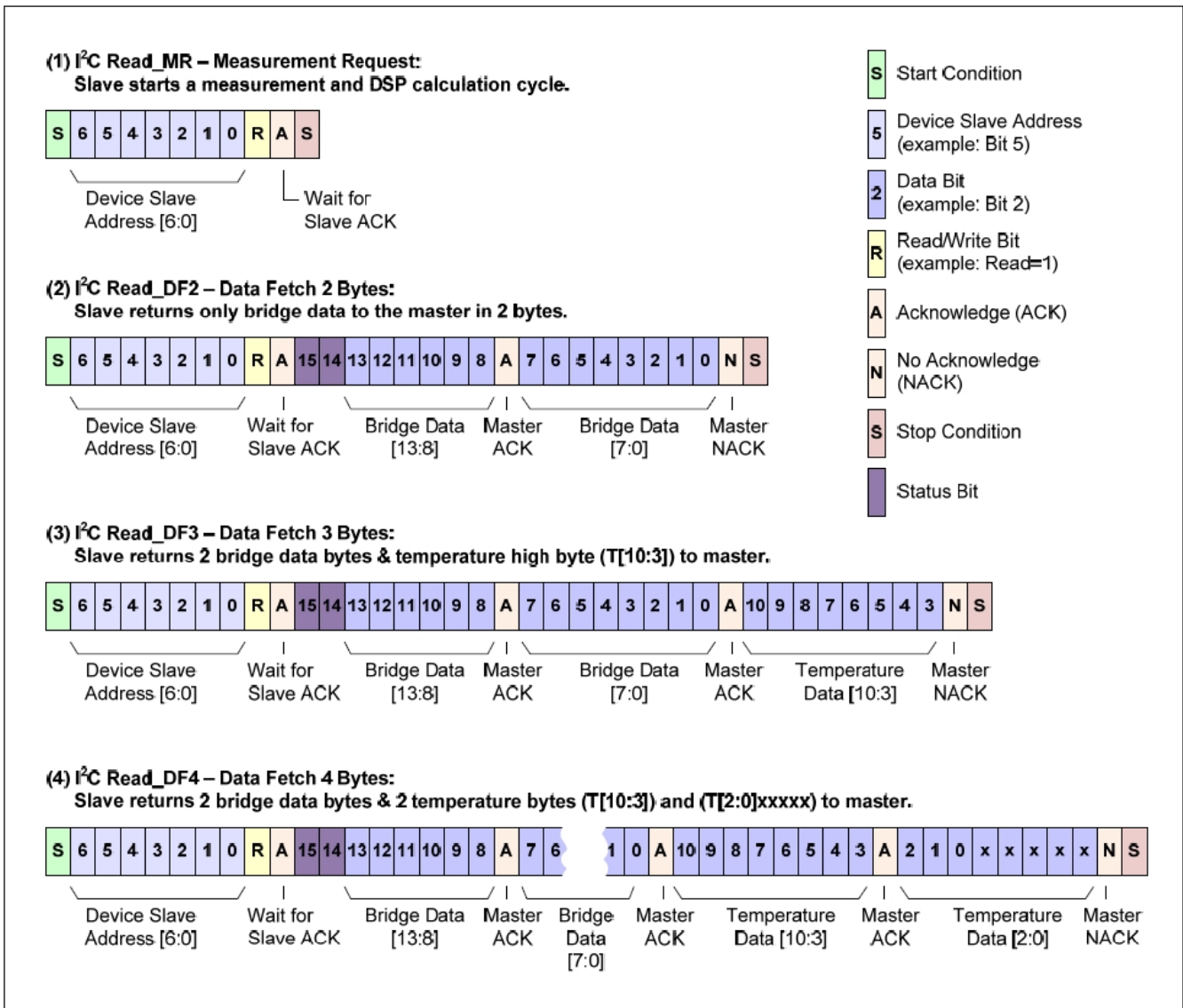

I²C interface parameter:

PARAMETERS	SYMBOL	MIN	TYP	MAX	UNITS
SCLK CLOCK FREQUENCY	f _{SCL}	100		400	KHz
START CONDITION HOLD TIME RELATIVE TO SCL EDGE	t _{HDSTA}	0.1			uS
MINIMUM SCL CLOCK LOW WIDTH ¹	t _{LOW}	0.6			uS
MINIMUM SCL CLOCK HIGH WIDTH ¹	t _{HIGH}	0.6			uS
START CONDITION SETUP TIME RELATIVE TO SCL EDGE	t _{SUSTA}	0.1			uS
DATA HOLD TIME ON SDA RELATIVE TO SCL EDGE	t _{HDDAT}	0			uS
DATA SETUP TIME ON SDA RELATIVE TO SCL EDGE	t _{SUDAT}	0.1			uS
STOP CONDITION SETUP TIME ON SCL	t _{SUSTO}	0.1			uS
BUS FREE TIME BETWEEN STOP AND START CONDITION	t _{BUS}	2			uS

¹ COMBINED LOW AND HIGH WIDTHS MUST EQUAL OR EXCEED MINIMUM SCL PERIOD.

I²C Clock:

