

## High frequency industrial vibration sensor



### Description

Model 310AM1 is an industrial IEPE accelerometer permitting extra high frequency vibration measurements. 310AM1 features an annular shear ceramic crystal which exhibits excellent output stability over time. The accelerometer incorporates an internal circuit with in a two-wire IEPE system which transmits its low impedance voltage output through the same cable that supplies the constant current power. Signal ground is internal shielded and isolated from the outer case of the unit. Polarity inversion protection for the amplify circuit is inherent in the circuit design. The welded stainless-steel construction provides a hermetic housing. The standard MIL-C-5015 glass insulated connector provides long-term stability over the operating temperature range. In addition to adhesive mounting, 310AM1 has 1/4-28 threaded holes for stud mounting on the test object. The 310AM1 provides wide frequency response and shock resistance, which is ideal for industrial vibration monitoring under incidental shock environment. Senter's model 16-L is a MIL-C-5015 connector mating cable for the sensor.

### Features

- Extra frequency range
- Corrosion resistant
- Hermetic seal
- Case isolated
- EMI / RFI shielded
- Shock resistance

### Application

- Windmill machine
- Gear box monitoring
- Bearing detection
- Machine monitoring

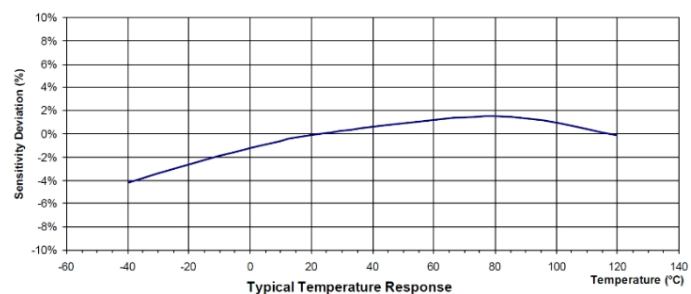
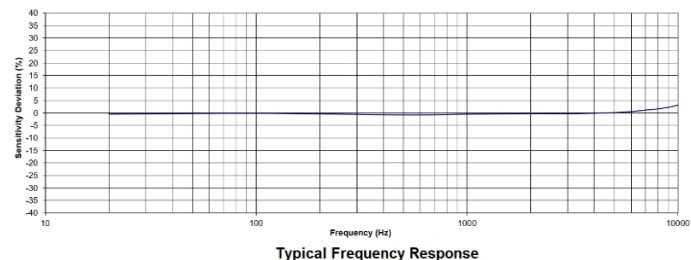
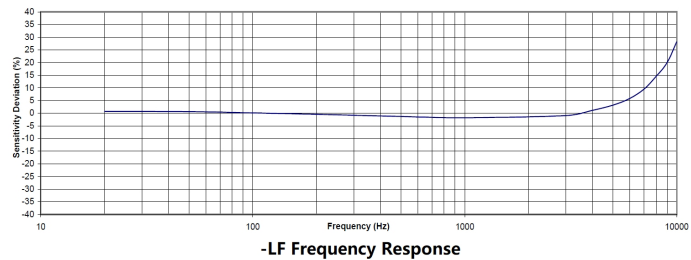
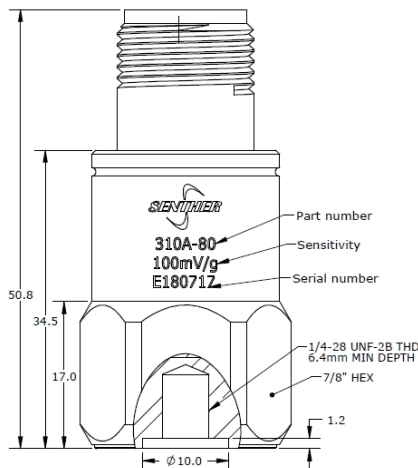
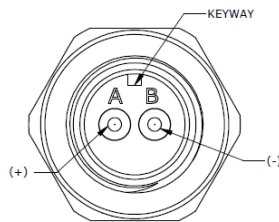

## Specification

Typical at +24°C (+75°F), 24Vdc, 4 mA and 100Hz, unless otherwise stated.

Part Number	-5-LF	-10-LF	-20	-80	-500	
Dynamic Range	±5	±10	±20	±80	±500	g, peak
Sensitivity ±10%	1000	500	250	100	10	mV/g
Freq. Resp. ±5%	0.3-5000	0.3-5000	2-7000	2-7000	2-7000	Hz
Freq. Resp. ±3dB	0.1-10000	0.1-10000	0.5-16000	0.5-16000	0.5-16000	Hz
Resonant Frequency	20	20	32	32	32	kHz
Transverse Sensitivity	<5	<5	<5	<5	<5	%
Temp. Resp., -55 to +125°C	±10	±10	±10	±10	±10	%
Non-Linearity	±1	±1	±1	±1	±1	%FSO
Residual Noise	0.00015	0.0002	0.0005	0.0005	0.0010	g RMS
Shock Limit	2000	2000	5000	5000	5000	g
Warm-up Time	<5	<5	<2	<2	<2	second
Weight	87	87	80	80	80	Gram

Specifications	Standard	Units
Bias Voltage	10 to 14	Vdc
Supply Voltage	18 to 30	Vdc
Supply Current	2 to 10	mA
Output Impedance	<100	Ω
Case Insulation (@100Vdc)	>100	MΩ
Operating Temperature	-55 to +125°C	°C
Humidity	Hermetically Sealed	
Case Material	316L Stainless Steel	
Sensing Element	Piezo Ceramic (Shear)	
Connector	2 Pin MIL-C-5015	

## Accessories

Calibration certificate included.

Part Number	Description	Availability
PM0011	Mounting stud ¼-28 to ¼-28 thread	One stud Included
PM0008	Mounting stud ¼-28 to M6 thread	
PM0007	Mounting stud ¼-28 to M10 thread	
PM0445	Adhesive mounting adapter	Optional
MB0001	Flat magnet mounting adapter	Optional
MB0011	Saddle magnet mounting adapter	Optional
16A-10	10 meter mating cable with MIL-C-5015 connector	Optional
16A-10-B	10 meter mating cable with MIL-C-5015 to BNC connector	Optional
IN-03	3 channels IEPE signal conditioner	Optional
IN-91	Portable vibration analyzer	Optional
IN-3062	8 channels data acquisition system	Optional

## Measurement configuration



## Ordering information

<b>310</b>	<b>AM1</b>	-	<b>80</b>	-	<b>LF</b>	-	<b>A</b>
<b>Model</b>	Output signal	-	Range	-	Low frequency option	-	Mounting stud
<b>310</b>	A=IEPE output M1=Extra frequency range	-	5=5g 10=10g 20=20g 80=80g 500=500g	-	LF= Low frequency response Blank= Standard FR	-	A= 1/4-28 to 1/4-28 thread B= 1/4-28 to M6 metric thread C*=Special

