

Single axial PE accelerometer



Features

- Corrosion resistant
- Hermetic seal
- ESD protection

Dynamic

Sensitivity, $\pm 20\%$, 25°C	6 pC/g
Acceleration range	2000 g peak
Amplitude nonlinearity.....	1%
Frequency response:	
$\pm 5\%$	3 - 5,000 Hz
$\pm 1\text{dB}$	1 - 10,000 Hz
$\pm 3\text{ dB}$	0.4 - 14,000 Hz
Resonance frequency.....	32 kHz
Transverse sensitivity, max.....	5% of axial
Temperature response:	
-50°C	-10%
$+125^{\circ}\text{C}$	+10%

Electrical

Power requirement:	Charge output
Output capacitor, max.....	1100 pF
Grounding.....	case ground

Environmental

Temperature range.....	-50 to 125°C
Vibration limit.....	2000 g peak
Shock limit.....	5,000 g peak
Electromagnetic sensitivity, equiv g, max	70 $\mu\text{g/gauss}$
Sealing	Hermetic
Base strain sensitivity, max.....	0.0002 g/ μstrain

Physical

Sensing element design.....	PZT ceramic/shear
Weight.....	12 grams
Case material.....	304L stainless steel
Mounting.....	10-32 UNF
Output connector.....	10-32
Recommended cabling.....	10-32 to BNC low noise

Accessories

Mounting stud: 10-32 to M5(-B), 10-32 to 10-32(-A), or custom(-C)
 Calibration certificate

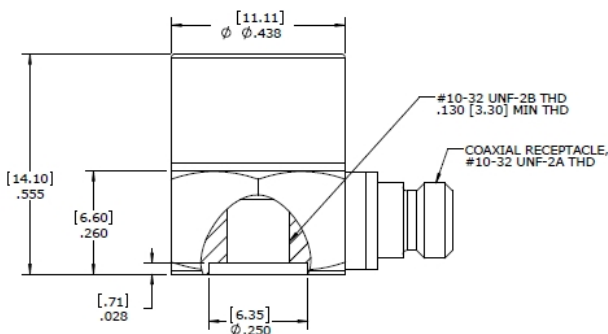
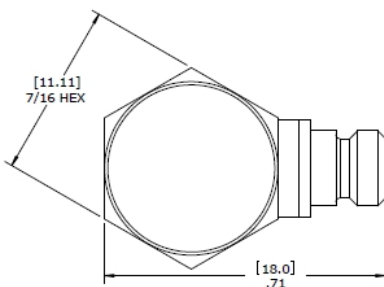

Ordering Information

